

Clog-Resistant Permeable Pavement: Methods of Performance Measurement

ZISHAN RAZA KHAN* and SYED AQEEL AHMAD

Department of Civil Engineering, Integral University, Lucknow.

Abstract

Permeable pavements are considered to be one of the effective measures for LID (i.e. Low Impact Development) and SUDS (i.e. Sustainable Urban Drainage System) globally. The major three types of permeable pavements are (a) pervious concrete (PC), (b) pervious asphalt (PA), and (c) permeable interlocked concrete paver (PICP). The performance of all types of permeable is satisfactory at the start of the service life but greatly reduced if not maintained on time. Considering the long lengths of the pavements, measurement of permeability at different locations is a cumbersome and tedious task. Therefore, ease of performance and realistic results are of vital importance. In this study, ASTM C1701/C1701M—17a single ring infiltrometer, Stormwater Infiltration Field Test (SWIFT), and NCAT permeameter Methods are discussed in detail and examined for their relative ease of setting-up, versatility and performance. It is concluded that ASTM C1701/C1701M—17a single ring infiltrometer is the most versatile, easy to set up and produces accurate results.



Article History

Received: 28 January 2023

Accepted: 21 June 2023

Keywords

Permeability Measurement; Permeable Pavement; Single Ring Infiltrometer; SWIFT Method; NCAT method; Low Impact Development.

Introduction

A properly designed road will ensure effective drainage of rainwater ensuring prolonged service life and effective service to road users.¹ Such roads allow quick removal of water from pavement surface minimizing loss of bitumen from bituminous roads. Slow removal of water from the bituminous top requires the use of modified bitumen with approximately 15% of polymer dosing or the use of Wetfix Be especially recommended for warmer climates.²⁻³ To achieve effective and low-cost

sustainable urban drainage system enabling quick removal of storm water which is economical also is a very important question and need of the hour. Permeable pavements are considered to be one of the effective measures for LID (i.e. Low Impact Development) and SUDS (i.e. Sustainable Urban Drainage System) in India as well as in other parts of the world.⁴⁻⁵ A Permeable pavement temporarily stores runoff water into its porous layers and later releases it at a controlled rate thus reducing and delaying the peak of runoff discharge. This retention

CONTACT Zishan Raza Khan ✉ zishanrk@iul.ac.in 📍 Department of Civil Engineering, Integral University, Lucknow.



© 2023 The Author(s). Published by Enviro Research Publishers.

This is an Open Access article licensed under a Creative Commons license: Attribution 4.0 International (CC-BY).

Doi: <https://dx.doi.org/10.12944/CWE.18.2.09>

period may be utilized for pollutant removal from runoff water, groundwater recharging, reducing the overall capacity of stormwater drainage system etc.⁴⁻⁶ There are three types of permeable pavement systems categorised based on the construct

of its top layer namely (a) pervious concrete (PC), (b) pervious asphalt (PA), and (c) permeable interlocked concrete paver (PICP).⁶ A sectional profile of PC, PA and PICP pavements are shown in Figure 1(a), 1(b) and 1(c).

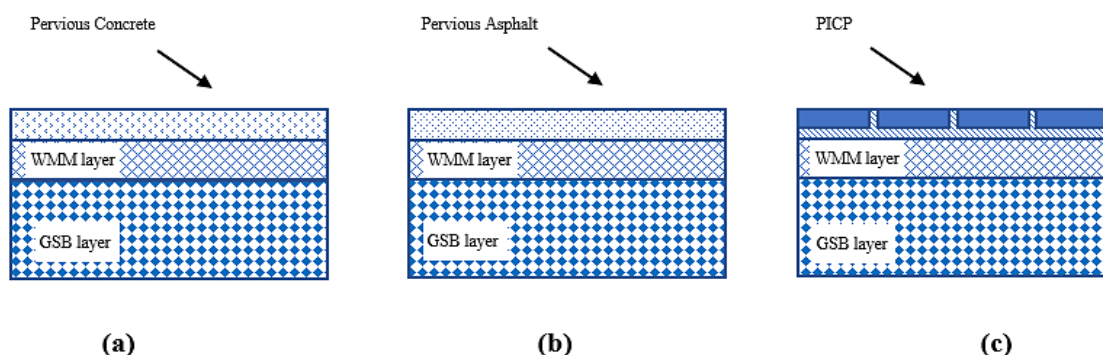

Fig. 1: A sectional profile of PC, PA and PICP pavement types with different layers.

The Wet Mix Macadam (WMM) layer is acting as a load dispersion layer and Granular Sub Base (GSB) layer is acting as *water* storage media due to its high porosity.⁶ MoRTH (Ministry of Road Transport and Highways), Government of India recommends for use of GSB Grade-III and in the USA use of AASHTO, No 2 aggregate is recommended for the Sub-base layer for permeable pavements.

All permeable pavements (i.e. PC, PA and PICP) exhibit high permeability in their first year of service and rapid reduction is observed in the following years.⁶ The prime reason for the reduction in permeability is clogging pores of the topmost layer of the pavement due to the accumulation of fines such as road dust etc. The rate of permeability reduction is very high and in a few cases reached near zero in as early as 3 years of service.⁷ Researchers had worked to control the clogging phenomenon and suggested regular cleaning to rejuvenate the permeable pavement performance. Several cleaning techniques were assessed, and pressure water-washing with vacuuming was found to be the most effective alternative but warrants high maintenance costs. Measurement of the rate of infiltration of the permeable pavement surface is the most reliable monitoring technique for the assessment of permeable pavement performance.

To maintain permeable pavement effectively, periodic assessment of pavement performance is

essential. Due to the longer lengths and variable usage conditions, several observations are required to assess actual pavement performance and identify such sections of the road which require maintenance. The fact that the road is continuously being used and temporarily shut down for testing causes problems for the users. Therefore, it is essential to choose a testing method which is quick to set up & execute and requires minimal equipment for easy transportation. There are three most prominent road permeability measurement methods (single ring infiltrometer method, NCAT method and SWIFT method) available and this study aims to explore the relative effectiveness and versatility of existing methods of permeability measurement to avoid/reduce the chances of clogging permeable pavement by taking timely corrective actions.

Clog-Resistant Permeable Pavement Technology
Porous Concrete (PC) Permeable Pavement
 Porous concrete has three types of pours for the effective permeability of the concrete (i) Effective pours, (ii) Semi effective pours and (iii) non-effective pours. The effective pours are those having considerable interconnected pore areas with low tortuosity. Semi-effective pours have interconnected pour areas with medium to high tortuosity, and non-effective pours are disconnected from other pours generally situated between two or more aggregate particles.⁸⁻⁹ It is generally considered that the high porosity of concrete results in better permeability

but this is not entirely true. Only interconnected pores contribute to the permeability of concrete. This is obvious that the higher the porosity better the chances of having (i) & (ii) type of pours. Moreover, especially type (ii) pours tend to choke much faster due to the high tortuosity path¹⁰. The total porosity is inversely proportional to the compressive strength of concrete; therefore, several efforts have been made by researchers by analyzing the combination of different aggregate sizes, w/c ratios and cement content to reduce type (iii) pours as compared to type (i) and (ii), but there is no established method to achieve it.¹¹

Porous Asphalt (PA) Permeable Pavement

Similar to PC, *Porous Asphalt (PA)* have an effective, semi-effective and non-effective pour system. The significant difference is due to the binder (asphalt) and particle size distribution.¹² Since asphalt has adhesion properties and a relatively low softening point, it tends to adhere to fine particles and fill the pours with 600 µm and 1.18 mm aperture. Studies established that in all the PA and PC mixes with different porosity, the PA mix always exhibits lesser permeability than the PC mix of the same porosity showing that the ratio of non-effective to total pours is higher than in PC mixes. The clogging behaviour of PA is similar to PC and permeability reduction with an increase in the age of pavement for both the mixes follows similar trends.¹³⁻¹⁴ The Maintenance and rejuvenation techniques for permeability of permeable pavements like regular vacuuming, pressure washing and vacuuming with pressure washing are the most acceptable.¹⁵ But methods for designing clog-resistance *Porous Asphalt* permeable pavement are not available.

Permeable Interlocking Concrete Pavers (PICP) for Permeable Pavement

A PICP pavement is a positive step towards developing clog-resistance permeable pavement. A Permeable pavement consisting of a top layer made up of interlocking concrete blocks utilizes the joint gap to transmit the water. This gap is filled with fine aggregate to lock the concrete blocks in their place and allow *water* passage.¹⁶ But clogging of joint filler material causes a reduction in permeability and ultimately leads to complete choking with fines. The PICP with vertical perforations is tested for its permeability by subjecting the test specimen

to several dry and wet clogging cycles. The test results show that low tortuosity (=1) perforations of 5-6mm diameter did not clog and maintained their permeability for pavement samples with 5% and above porosity.¹⁷ However, the performance of such PICP with bedding layers has not been tested. The large aperture of paver blocks (Joints gaps) helps in prolonging the complete choking of interlocking concrete block pavements but a reduction in permeability is inevitable. Furthermore, a high-pressurized air and vacuum system are found to be the most effective maintenance method for permeability restoration.¹⁸

Performance Assessment Methods of Permeable Pavement

The runoff *water* accumulating on the top layer of permeable pavements must be allowed to pass through and infiltrate into WMM and GSB layers to temporarily store in the pours. This stored *water* eventually exfiltrates into neighbouring natural soil strata. It is essential to assess that permeable pavement is working and efficiently infiltrates the surface water, the surface infiltration test has to be performed periodically at a different location on the site. The results of the tests govern the maintenance requirements of permeable pavement.

The Infiltration Rate Measurement of Pervious Concrete (PC) using ASTM C1701/ C1701M-17 (a) Single Ring Infiltrometer Method

This method is divided into four steps; (i) Installation of an infiltration ring of 300mm diameter on the test pavement with the help of putty used by plumbers, at the outer boundary of concrete-ring interface to prevent leakage of *water* (Figure 2 a, b, c) (ii) prewetting of concrete with almost 1 gallon (8 lb) of *water* poured into the infiltration ring in with such rate that maintains *water* level between 10-15mm level mark. This prevents any local absorption of *water* and reduces error. (iii) Within 2 min of wetting, pour 40lb of *water* to maintain the *water* head in the ring between 15mm and 10mm. Note down the time elapsed between at *water* hitting the surface till all drains down with 0.1-sec accuracy (iv) calculate the infiltration rate as per the following formula

$$I = \frac{KM}{D^2 t}$$

I → Rate of Infiltration in millimetre/h (or in./h)

M → Water-Mass which is infiltrated in kg (or lb)
 D → Internal diameter of the infiltration ring in mm
 (or in.)

T → Time (sec) (infiltration time)
 K → 4,583,666,000 (SI units) / 126,870 (inch-
 pound units)

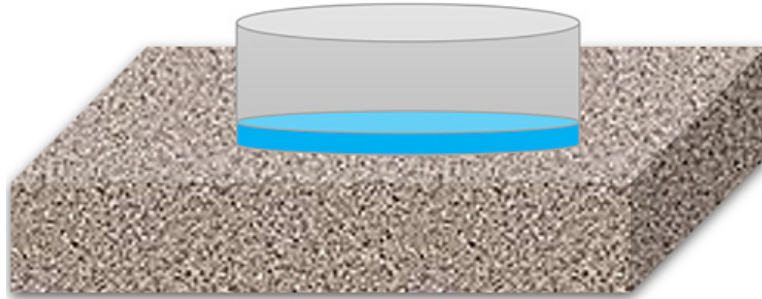

(a)

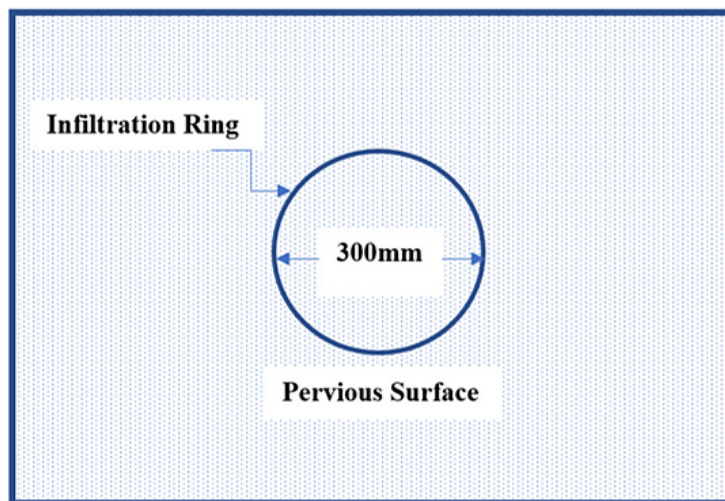

(b)

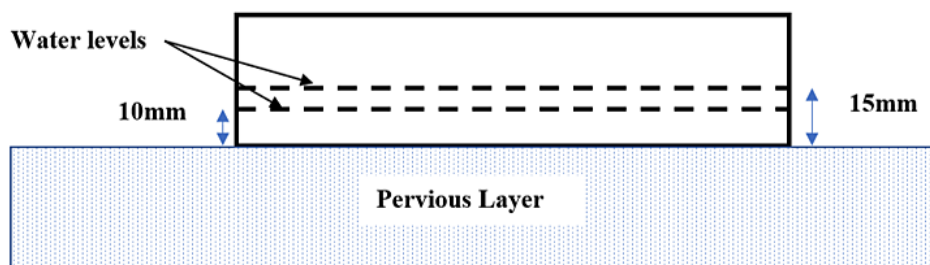

(c)

Fig. 2: Single ring infiltrometer method (a) animated 3D view (b) Plan and (c) sectional elevation of the setup

Single ring infiltrometer test (SRIT) method is suitable for measuring the infiltration rate of pavement made up of PA and PICP. SRIT is also suitable for measuring the infiltration capacity of clogged pavement.

The Infiltration Rate of Permeable Pavement using S.W.I.F.T. (Stormwater Infiltration Field Test) Method

This method is developed to keep simplicity in mind and requires very little instrumentation. The test can be performed using a 20L bucket with a 40mm diameter hole in the centre of the bottom. This hole is fitted with a plug attached to a string to prevent

water leakage when plug-in and easy release of water when needed. The test setup is described in Figure 3.

The S.W.I.F.T. method⁶ works on the basic principle of 'higher the filtration rate, better the condition of the pavement, lesser the number of wetted blocks with the same amount of water'. SWIFT method realizes on counting the wetted blocks thus no prewetting is required. If repeat tests are needed at the exact same section of the pavement tested earlier a minimum of 24hr gap should be provided to let it dry. The test steps are as follows

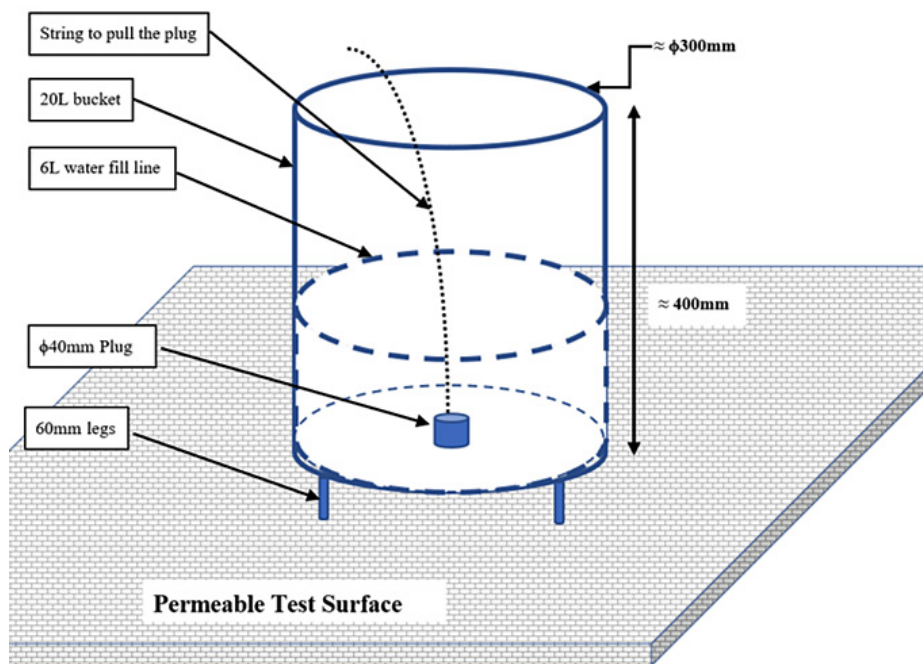

Fig. 3: S.W.I.F.T. (Stormwater Infiltration Field Test) Method setup

Step (i) Locate any paver block from the test surface and place a 20L bucket in such a way that the drainage hole centres the chosen block.

Step (ii) Plug-in the drainage hole tightly and pour 6L of water into the bucket.

Step (iii) By pulling the string, remove plug and let all water drain.

Step (iv) Remove the device and count only that blocks which have a completely wet surface. Record the numbers. A photograph of the wetted surface may be recorded for further analysis.

v) Using Table 1, the condition of the PICP pavement may be inferred

Table 1: SWFIT test results and Condition of PICP pavement

SWIFT result (Number of fully wetted blocks)	Pavement Condition	Maintenance Requirement
<29	Fully Functional (unblocked)	Not required
29-133	Partially Functional (medium blockage)	Required in near future (1-3 years)
>133	Non-Functional (Completely Blocked)	Immediate

NCAT Permeameter

In the year 1999, Allen L. Cooley,¹⁹ NCAT (The National Center for Asphalt Technology), USA developed a field test method to determine the permeability of porous pavements. The working principle of this permeameter is falling-head

of water column and is widely used for permeability assessment of OGFC (Open Graded Friction Course) and pervious asphalt (PA) pavement. An animated 3D view of NCAT permeameter is presented below in Figure-4.

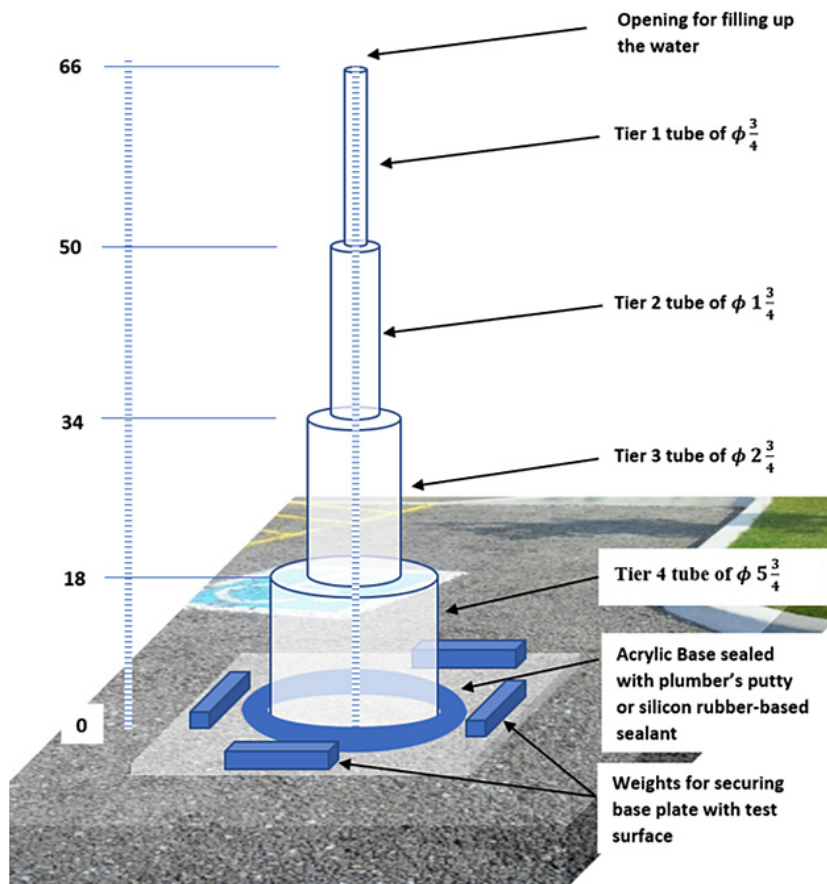

Porous Asphalt Surface

*All dimensions are in inches

Fig. 4: NCAT permeameter test apparatus setup with dimensions

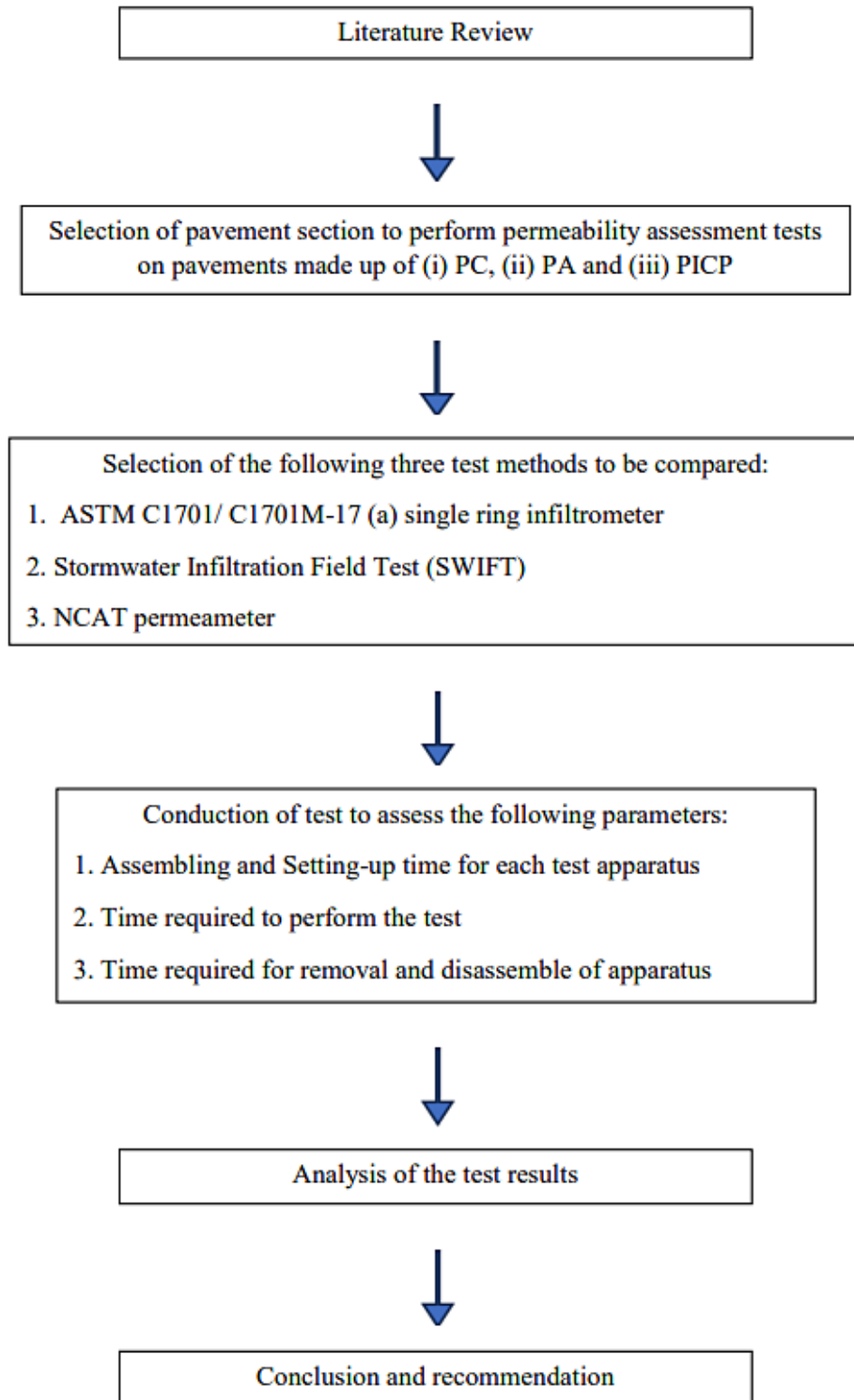

NCAT permeameter is consisting four detachable acrylic tubes (0.75, 1.75, 2.75 & 5.75 inches) tiered

one over other. Smallest diameter tube is placed on top and largest diameter tube is in bottom.

Only 5.75-inch diameter tube may be utilized to measure permeability of highly permeable surfaces and smaller diameter tubes are useful in case of lower permeability surface measurements. Base on the apparent permeability, appropriate tube combinations were selected and using plumber's putty instrument is mounted on test surface in such a way that no lateral leakage is observed. *Water* is poured in the graduated tube/s from the top till tubes are completely filled. Elapsed time is recorded using a stopwatch for the level of *water* to fall from each tier of permeameter.

The recorded time to drop one tier is to be used to measure the permeability coefficient (K), which is also described as the hydraulic conductivity of the material in the saturated state. Saturated Permeability (K_s) is calculated using following equation

$$K_s = \frac{al}{At} \ln \left(\frac{h_1}{h_2} \right)$$

where:

- K_s → Hydraulic conductivity (Saturated) in cm/sec
- a → Internal area of the inlet cylinder, cm-square
- l → Thickness of pavement, cm
- A → Sectional area of the teat pavement, cm²
- t → Time elapsed (average) by *water* to fall (t_1 - t_2), sec
- h_1 → Head measured at time t_1 (in cm)
- h_2 → Head measured at time t_2 (in cm)

While performing a permeability test using an NCAT permeameter, one of the critical factors is to develop a no-leak seal between the base plate and the test surface. Although, plumber's putty is widely used, but new silicon rubber-based sealant products are available in the market which ensures an even better seal and prevent any leakages.²⁰ A sufficient quantity of silicon rubber-based sealant is placed along the periphery of the vertical tube at the base in an inverted position and leave it for 2-3min. Turn the permeameter upright and carefully mount it on the surface under test. Secure the base plate with weights provided by placing them on the base plate. Before the commencement of the test, ensure that there is no lateral movement in the apparatus by pushing it with a little lateral force at the base plate.

Methodology and Test Results

To achieve the objectives of the current study the following methodology was adopted.

To perform the test 10 sections on each type of road is identified. All the three apparatus were installed, perform the test and removal with disassembling had been done. Table 2 contained the data collected.

Results and Discussion

Table 2: Results showing the time required to conduct permeability assessment test on permeable pavement

S. No	Type of Permeable Pavement	Road Section No	SRI*				NCAT**				SWIFT***			
			AT#	PT#	RT#	TT#	AT#	PT#	RT#	TT#	AT#	PT#	RT#	TT#
1	Porous	R _{PC} -01	230	151	10	391	415	265	275	955	Not compatible with porous concrete pavement			
2	Concrete	R _{PC} -02	215	148	8	371	417	275	255	947				
3		R _{PC} -03	226	135	8	369	426	290	265	981				
4		R _{PC} -04	221	142	10	373	435	260	250	945				
5		R _{PC} -05	232	146	10	388	415	275	263	953				
6		R _{PC} -06	220	145	9	374	428	255	266	949				
7		R _{PC} -07	228	138	7	373	425	265	245	935				
8		R _{PC} -08	215	155	8	378	430	270	255	955				
9		R _{PC} -09	219	150	10	379	428	260	260	948				
10		R _{PC} -10	235	144	10	389	410	270	245	925				
		Avg	224.1	145.4	9	378.5	422.9	268.5	257.9	949.3				

S. No	Type of Permeable Pavement	Road Section No	SRI*				NCAT**				SWIFT***			
			AT#	PT#	RT#	TT#	AT#	PT#	RT#	TT#	AT#	PT#	RT#	TT#
		SD	6.73	5.73	1.1	7.65	7.67	9.5	9.22	13.80				
		Conf Level		95%				95%						
		T-test result		Significant				Significant						
1	Porous	R _{PA} -01	225	148	10	383	405	265	270	940	Not compatible with porous asphalt pavement			
2	Asphalt	R _{PA} -02	218	148	10	376	410	275	260	945				
3		R _{PA} -03	232	135	7	374	410	278	265	953				
4		R _{PA} -04	225	142	10	377	424	268	265	957				
5		R _{PA} -05	240	145	10	395	422	275	264	961				
6		R _{PA} -06	228	145	10	383	428	265	266	959				
7		R _{PA} -07	230	140	7	377	425	268	245	938				
8		R _{PA} -08	230	150	7	387	420	271	265	956				
9		R _{PA} -09	235	145	10	390	428	258	260	946				
10		R _{PA} -10	235	144	9	388	410	270	245	925				
		Avg	229.8	144.2	9	383	418.2	269.3	260.5	948				
		SD	5.93	4.14	1.34	6.6	8.16	5.59	8.21	10.8				
		Conf Level		95%				95%						
		T-test result		Significant				Significant						
1	Permeable interlocking concrete pavers	RPCIP-01	228	128	9	365	456	253	265	974	57	284	22	363
2		RP _{CIP} -02	193	152	13	358	470	311	272	1053	35	306	18	359
3		RP _{CIP} -03	190	112	12	314	467	317	248	1032	45	309	19	373
4		RP _{CIP} -04	189	122	7	318	465	254	238	957	31	290	22	343
5		RP _{CIP} -05	218	148	7	373	438	281	268	987	46	290	23	359
6		RP _{CIP} -06	195	124	8	327	475	280	255	1010	40	295	19	354
7		RP _{CIP} -07	190	112	6	308	467	248	235	950	46	285	22	353
8		RP _{CIP} -08	215	113	13	341	480	258	278	1016	53	304	15	372
9		RP _{CIP} -09	199	147	11	357	486	260	265	1011	56	298	15	369
10		RP _{CIP} -10	231	154	13	398	438	275	265	978	51	295	22	368
		Avg	204.8	131.2	9.9	345.9	464.2	273.7	258.9	996.846	296	19.7	361.3	
		SD	15.68	16.43	2.66	27.74	15.27	22.96	13.69	31.448.23	8.21	2.83	9.09	
		Conf Level		95%				95%				95%		
		T-test result		Significant				Significant				Significant		

* - ASTM C1701/ C1701M-17 (a) single ring infiltrometer

** - National Center for Asphalt Technology (NCAT) permeameter

*** - Stormwater Infiltration Field Test (SWIFT)

- AT: Assembling and Setting-up time, PT: Time required to perform the test, RT: Time required for removal and disassemble of apparatus, TT: Total Time (All observations are in seconds)

The methods described above based on test results can be classified based on the following parameters

S. No.	Title of the method	Type/s of Permeable Pavement Suited for based on time required to perform the test			Working principle and use	Ease of installation
		Porous concrete	Porous Asphalt	PICP		
1	ASTM C1701/C1701M—17a single ring infiltrometer method	YES (M=378 ±11, SD =7.65)	YES (M=383 ±10, SD =6.60)	YES (M=346 ±45, SD =27.74)	Falling head of water column	Very easy to set up and perform the test. Several tests can be performed on a small stretch of the road.
2	Stormwater Infiltration Field Test (SWIFT) Method	NO	YES (M=361 ±15, SD =9.09)	NO	Low Spread of water on the pavement implies to Highly permeability and visa-versa	Easy, requires considerable time for a second and subsequent test on the same spot
3	NCAT permeameter Method	YES (M=949 ±28, SD =13.8)	YES (M=948 ±18, SD =10.8)	YES (M=997 ± 52, SD= 31.4)	Falling head of water column	Easy set-up, requires a little training to perform the test. The major challenge is to achieve a proper seal as required by the test procedure.

Conclusion

Based on the effectiveness and versatility of the permeability measurement methods described above it may be concluded as

- i. ASTM C1701/C1701M—17a single ring infiltrometer method may be used for porous concrete, porous asphalt and PIC pavements' performance assessment by measuring its' permeability.
- ii. Stormwater Infiltration Field Test (SWIFT) Method is only suitable for ICB pavements' performance assessment.
- iii. NCAT permeameter Method may be used for porous concrete and porous asphalt pavements' performance assessment by measuring its' permeability. The use of this method on PCIP pavement requires trained personnel since achieving a proper seal poses a challenge.

- iv. Time required to run the test with SRI and SWIFT is almost identical.
- v. Permeability measurement test using NCAT permeameter requires almost triple the time as compared to SRI or SWIFT.

Acknowledgement

I acknowledge and extend my gratitude towards Mr. Syed Sufiyan Abbasi, Director of Procurement and the staff members of the Department of Civil Engineering, Integral University, Lucknow for their support.

Funding

This work is being funded by Integral University, Lucknow as a seed grant for research.

Conflict of Interest

There is no conflict of interests.

References

1. Awwad, M. (2021). Studying the effects of roads geometry and design parameters on the pavement drainage system. *Civ. Eng. J*, 7, 49-58.
2. Al-Hasan, S. J. A., Balamuralikrishnan, R., & Altarawneh, M. (2020). Eco-friendly asphalt approach for the development of sustainable roads. *Journal of Human, Earth, and Future*, 1(3), 97-111.
3. Nawir, D., & Mansur, A. Z. (2022). Effects of HDPE Utilization and Addition of Wetfix-Be to Asphalt Pavement in Tropical Climates. *Civil Engineering Journal*, 8(8), 1665-1678.
4. Zhou, Qianqian. "A review of sustainable urban drainage systems considering the climate change and urbanization impacts." *Water* 6.4 (2014): 976-992.
5. Santhanam, Harini, and Rudrodip Majumdar. "Permeable pavements as sustainable nature-based solutions for the management of Urban Lake Ecosystems." *Nature-based solutions for resilient ecosystems and societies*. Springer, Singapore, 2020. 329-345.
6. Lucke, Terry, *et al.* "A simple field test to evaluate the maintenance requirements of permeable interlocking concrete pavements." *Water* 7.6 (2015): 2542-2554.
7. Rodriguez-Hernandez, Jorge, *et al.* "Characterization of infiltration capacity of permeable pavements with porous asphalt surface using cantabrian fixed infiltrometer." *Journal of Hydrologic Engineering* 17.5 (2012): 597-603.
8. Bear, Jacob. *Dynamics of fluids in porous media*. Courier Corporation, 1988.
9. Cai, Jiwei, *et al.* "A novel approach to evaluate the clogging resistance of pervious concrete." *Case Studies in Construction Materials* 16 (2022): e00864.
10. Koohmishi, Mehdi, and Gholamali Shafabakhsh. "Drainage potential of reservoir course of porous pavement for various particle size distributions of aggregate." *Transportation Geotechnics* 16 (2018): 63-75.
11. Ćosić, K., *et al.* "Influence of aggregate type and size on properties of pervious concrete." *Construction and Building Materials* 78 (2015): 69-76.
12. Fwa, T. F., Lim, E., & Tan, K. H. (2015). *Comparison of Permeability and Clogging Characteristics of Porous Asphalt and Pervious Concrete Pavement Materials*. *Transportation Research Record: Journal of the Transportation Research Board*, 2511(1), 72–80. doi:10.3141/2511-09
13. Fwa, T., Tan, S., & Chuai, C. (1998). *Permeability Measurement of Base Materials Using Falling-Head Test Apparatus*. *Transportation Research Record: Journal of the Transportation Research Board*, 1615, 94–99. doi:10.3141/1615-13
14. Tan, S. A., T. F. Fwa, and Y. K. Guwe. Laboratory Measurements and Analysis of Clogging Mechanism of Porous Asphalt Mixes. *Journal of Testing and Evaluation*, Vol. 28, No. 3, 2000, pp. 207–216.
15. Hu, Nian, *et al.* "A field performance evaluation of the periodic maintenance for pervious concrete pavement." *Journal of Cleaner Production* 263 (2020): 121463.
16. Danz, Mari E., William R. Selbig, and Nicolas H. Buer. "Assessment of restorative maintenance practices on the infiltration capacity of permeable pavement." *Water* 12.6 (2020): 1563.
17. Kia, A., H. S. Wong, and C. R. Cheeseman. "Control of clogging in conventional permeable concrete and development of a new high strength clogging resistant permeable concrete pavement." *J. Environ Manage* (2018).
18. Drake, Jennifer, T. Sarabian, and S. Jody. "Maintenance Equipment Testing on Accelerated Clogged Permeable Interlocking Concrete Pavements." *Interlocking Concrete Pavement Institute, Chantilly, VA* (2020).
19. Cooley, L. Allen. *Permeability of superpave mixtures: Evaluation of field permeameters*. No. Report No: NCAT 99-1. National Center for Asphalt Technology, 1999.
20. Li, Hui, Masoud Kayhanian, and John T. Harvey. "Comparative field permeability measurement of permeable pavements using ASTM C1701 and NCAT permeameter methods." *Journal of environmental management* 118 (2013): 144-152.